



US 20050104513A1

(19) **United States**

(12) **Patent Application Publication** (10) **Pub. No.: US 2005/0104513 A1**

Lee et al.

(43) **Pub. Date: May 19, 2005**

(54) **ORGANIC ELECTROLUMINESCENT DISPLAY**

(30) **Foreign Application Priority Data**

Nov. 17, 2003 (KR)..... 2003-81209

(76) Inventors: **Ho-Seok Lee, Yongin-si (KR);
Won-Kyu Choe, Seoul (KR)**

Publication Classification

(51) **Int. Cl.⁷** **H05B 33/00; H05B 33/04**

(52) **U.S. Cl.** **313/506; 313/512**

Correspondence Address:
**MCGUIREWOODS, LLP
1750 TYSONS BLVD
SUITE 1800
MCLEAN, VA 22102 (US)**

(57) **ABSTRACT**

In particular, one embodiment of the present invention provides an organic electroluminescent display which comprises a light emitting device formed on a lower insulating substrate, and an upper substrate mounted to encapsulate the light emitting device, wherein the upper substrate is provided with a desiccant, the desiccant being formed with at least one hole passing through the desiccant.

(21) Appl. No.: **10/989,022**

(22) Filed: **Nov. 16, 2004**

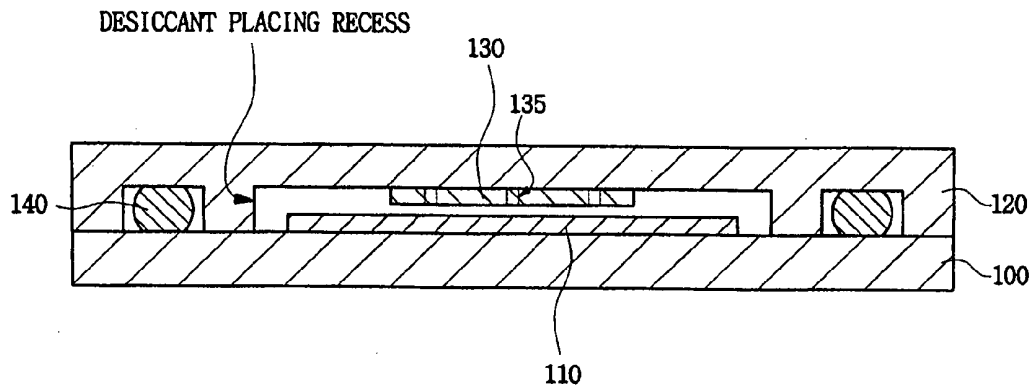

FIG. 1

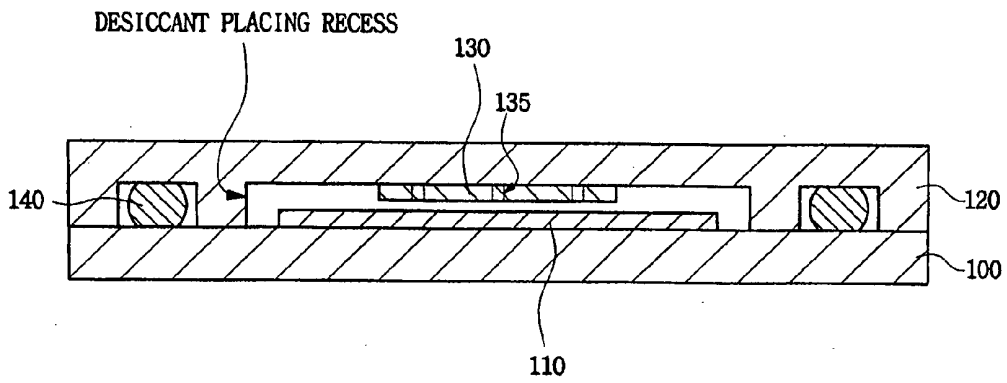

FIG. 2A

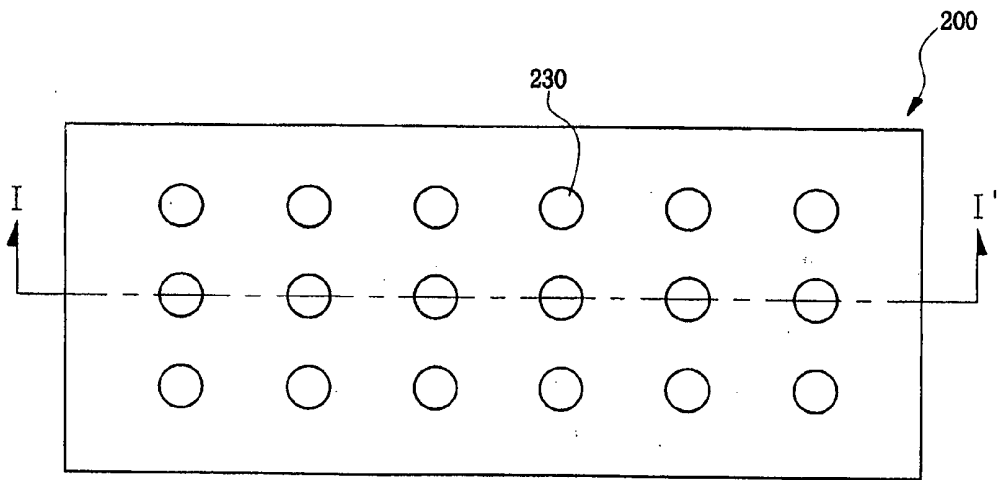
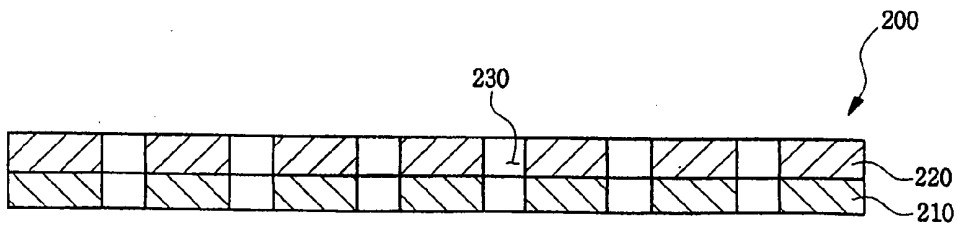

FIG. 2B



ORGANIC ELECTROLUMINESCENT DISPLAY

CROSS-REFERENCE TO RELATED APPLICATION

[0001] This application claims the benefit of Korean Patent Application No. 2003-81209 filed on Nov. 17, 2003, which is herein incorporated by reference.

BACKGROUND OF THE INVENTION

[0002] 1. Field of the Invention

[0003] The field of the present invention relates to organic electroluminescent displays (OLEDs) generally, and, more particularly, to an OLED containing a desiccant formed with holes therein which prevent bubbles from forming when the desiccant is adhered to a substrate or other substantially planar surface.

[0004] 2. Description of the Related Art

[0005] OLEDs offer a thinner dimension, wider viewing angle, lighter weight, smaller size, quicker response time, and lower power consumption, as compared to a cathode ray tube (CRT) display or liquid crystal display (LCD). Moreover, OLEDs can be easily fabricated using simple manufacturing processes because its simple structure includes only three major elements, namely an anode electrode, an organic material layer, and a cathode electrode. Because of these and other advantages OLEDs are emerging as the next generation of flat panel displays.

[0006] In an OLED configured in the conventional manner, an organic light emitting device is formed on a lower insulating substrate, with an upper substrate disposed above the organic light emitting device.

[0007] A significant disadvantage associated with this configuration is that materials used to form the organic light emitting layer and cathode electrode have insufficient resistance against moisture and/or oxidation. This weakness deteriorates the reliability of the display over time. In particular, internal oxidation and/or accumulation of moisture causes areas of the display to become non-emissive. Such non-emissive areas are called "dark spots". As time goes by, the dark spots spread to neighboring areas and eventually destroy the entire display.

[0008] In an attempt to solve the foregoing problem, a conventional OLED encapsulates the organic light emitting layer and the cathode electrode to protect them against moisture and oxygen. The process involves forming a desiccant placing recess in an encapsulation substrate made of a glass material; adhering a desiccant in the recess; and bonding the encapsulation substrate to an insulating substrate with a sealant. The bonding process is performed in an inert gas such as nitrogen (N₂), argon (Ar) or the like, to prevent the encapsulation of atmospheric moisture and oxygen.

[0009] Conventionally, the desiccant material is formed on a layer of adhesive material and to a thickness of about 200 μ m. The desiccant material is made of barium oxide (BaO), calcium carbonate (CaCO₃), calcium oxide (CaO), phosphor oxide (P₂O₅), Zeolite, Silicagel, Alumina, and like elements and compounds which eliminate moisture by physisorption or chemisorption.

[0010] A significant disadvantage of using the method described above is that a gas trapped between the desiccant and a substrate will form bubbles as the desiccant is adhered to the substrate. The bubbles place portions of the desiccant into contact with the organic light emitting device, which is problematic because the moisture accumulated by the desiccant eventually penetrates the organic light emitting device and makes it non-emissive.

[0011] Conventional attempts to solve the bubble problem included forming a deep desiccant placing recess to a depth of about 350 μ m. This depth prevented protruding and non-protruding areas of the bubble-deformed desiccant from contacting the light-emitting device. However, because the thickness of the substrate is proportional to the depth of the desiccant placing recess, the deep desiccant placing recess necessitates a thick substrate. This, in turn, creates a heavier OLED.

SUMMARY OF THE INVENTION

[0012] In one embodiment of the present invention, the OLED includes a desiccant formed with at least one hole therein. The hole prevents bubbles from forming when the desiccant is adhered to a substrate or other substantially planar surface by permitting gas trapped between the desiccant and the substrate to escape.

[0013] In particular, one embodiment of the present invention provides an organic electro luminescence display, comprising: a light emitting device formed on a lower insulating substrate; and an upper substrate mounted to encapsulate the light emitting device, wherein the upper substrate is provided with a desiccant, the desiccant being formed with at least one hole passing through the desiccant.

BRIEF DESCRIPTION OF THE DRAWINGS

[0014] FIG. 1 is a cross-sectional view illustrating an organic electroluminescent display configured in accordance with an embodiment of the present invention.

[0015] FIG. 2A is a plan view illustrating a desiccant used in an organic electroluminescent display configured in accordance with an embodiment of the present invention.

[0016] FIG. 2B is a cross-sectional view taken along line I-I' of FIG. 2A.

[0017] In the drawings, the thickness of layers and regions are exaggerated for clarity.

DETAILED DESCRIPTION OF THE INVENTION

[0018] FIG. 1 is a cross-sectional view of an organic electroluminescent display configured in accordance with an embodiment of the present invention.

[0019] As shown in FIG. 1, the organic electroluminescent display includes a lower insulating substrate 100, an organic light emitting device 110 formed on the lower insulating substrate 100, and an upper substrate 120 having a desiccant placing recess 137 to which a desiccant 130 is adhered with at least one hole 135 is adhered to an inner surface of the desiccant placing recess 137. The hole 135 of the desiccant 130 acts to prevent bubbles from forming as the desiccant 130 is adhered to the upper substrate 120.

[0020] As shown, the upper substrate **100** further includes sealing recesses **150A**, **150B**, which bond to a sealant **140A**, **140B**, such that the upper substrate **120** is bonded to the lower substrate and encapsulates the organic, light-emitting device **110**.

[0021] In one embodiment, the organic light emitting device **110** includes a first electrode, an organic emission layer, and a second electrode, wherein when the first electrode is used as an anode electrode, the second electrode is used as a cathode electrode, and vice versa.

[0022] The organic emission layer can be composed of various layers according to its function. In one exemplary embodiment, the organic emission layer is of a multiple-layer structure that includes an emission layer and at least one of a hole injecting layer (HIL), a hole transporting layer (HTL), a hole blocking layer (HBL), an electron transporting layer (ETL) and an electron injecting layer (ETL).

[0023] The layer of desiccant **130** is made of at least one material selected from a group consisting of barium oxide (BaO), calcium carbonate (CaCO₃), calcium oxide (CaO), phosphor oxide (P₂O₅), Zeolite, Silicagel, Alumina, and the like. A layer of adhesive material such as a sticker or adhesive thin film, may be used to adhere the desiccant **130** to the upper substrate **120**. In one embodiment, the desiccant **130** is a strip of preformed material.

[0024] FIG. 2A is a plan view illustrating a desiccant used in an OLED configured in accordance with an embodiment of the present invention. FIG. 2B is a cross-sectional view taken along line I-I' of FIG. 2A.

[0025] Referring to FIGS. 2A and 2B, desiccant **200** may include a layer of desiccant material **220** formed on a layer of adhesive material **210**. A plurality of holes **230** formed in the desiccant **200** pass through the desiccant **200** from side to side. The layer of desiccant material **220** absorbs moisture, and the sealant **140A**, **140B** affixes the desiccant **200** to the upper substrate **120**. In one embodiment, the layer of desiccant material **220** has a thickness of less than about 200 μm .

[0026] The holes **230** prevent gas bubbles from forming when the desiccant **200** is adhered to the upper substrate **120**, and may have various shapes such as, but not limited to, circular, rectangular, and triangular shapes. To effectively prevent the formation of the bubbles, each hole **230** should have a circular shape of diameter of more than about 1.0 mm. In one embodiment the diameter of each hole is in the range of about 1.0 mm to about 2.0 mm. If the diameter of the hole **230** is too small, bubbles will form as the desiccant **200** is adhered. Oppositely, if the diameter of the hole **230** is too large, it is difficult to keep the desiccant **200** in a film form, and there are problems adhering the desiccant **200** to the substrate **120**.

[0027] In an exemplary embodiment, the holes **230** formed through the desiccant **200** occupy an area of less than 6% of the total area of the desiccant **200**. In particular, the holes **230** may occupy an area in the range of about 1% to about 6% of the total area of the desiccant **200**. If the area occupied by the holes exceeds more than about 6%, the desiccant's moisture absorbing qualities tend to decrease.

[0028] On the other hand, the number of the holes **230** formed in the desiccant **200** may increase as the area of the

desiccant **200** increases. Thus a large desiccant **200** may include more holes than a smaller desiccant. In one embodiment, the desiccant holes number between about 13,000/m² to 20,000/m², and are formed to extend through the desiccant material from a top surface thereof to a bottom surface thereof.

[0029] To prevent the formation of bubbles the desiccant **200** may be formed with at least one hole per 1 cm².

[0030] In an OLED configured as described above, gas bubbles are prevented from forming between the desiccant **130**, **200** and the upper substrate (**120**) because a gas normally trapped between the desiccant and the substrate is released through the holes **230**. Releasing the trapped gas causes the desiccant **130**, **200** to lie flat without contacting the organic light-emitting device. Two benefits incur from this. First, the formation of dark spots is prevented. Second, the desiccant placing recess can be formed in depths of about 350 μm . or less, as measured from an inner surface **160** of the recess on which the desiccant is adhered to an outer surface **170** of the substrate **100** on which the light-emitting device is formed.

[0031] In this manner, the thickness of the upper substrate **120** can be reduced to create a lightweight OLED suitable for mobile transport.

[0032] While the present invention has been described with reference to embodiments, it is understood that the disclosure has been made for purpose of illustrating the invention not to limit the scope of the invention. The embodiments herein described may be modified and changed without departing from the scope and spirit of the invention.

What is claimed is:

1. An organic electroluminescent display, comprising:

a light emitting device formed on a lower insulating substrate; and

an upper substrate mounted to encapsulate the light emitting device,

wherein the upper substrate is provided with a desiccant, the desiccant being formed with at least one hole passing through the desiccant.

2. The organic electroluminescent display as claimed in claim 1, wherein the upper substrate is provided with a desiccant placing recess.

3. The organic electroluminescent display as claimed in claim 1, wherein the hole of the desiccant prevents bubbles from forming while the desiccant is adhered.

4. The organic electroluminescent display as claimed in claim 1, wherein the hole of the desiccant has one of circular, triangular, and rectangular shapes.

5. The organic electroluminescent display as claimed in claim 4, wherein the hole of the desiccant has the circular shape.

6. The organic electroluminescent display as claimed in claim 5, wherein when the hole of the desiccant has the circular shape, the hole has a diameter of more than 1 mm.

7. The organic electroluminescent display as claimed in claim 6, wherein the hole of the desiccant has a diameter of 1 mm to 2 mm.

8. The organic electroluminescent display as claimed in claim 1, wherein the holes occupy an area of less than 6% of the whole area of the desiccant.

9. The organic electroluminescent display as claimed in claim 8, wherein the holes occupy an area of 1% to 6% of the whole area of the desiccant.

10. The organic electroluminescent display as claimed in claim 1, wherein the number of the holes is between 13,000/m² and 20,000/m².

11. The organic electroluminescent display as claimed in claim 1, wherein the desiccant is provided with at least one hole per 1 cm².

12. The organic electroluminescent display as claimed in claim 1, wherein the depth of the desiccant placing recess is less than 350 μm.

13. The organic electroluminescent display as claimed in claim 1, wherein the desiccant is composed of a desiccant material layer and an adhesive material layer, the adhesive material layer being employed to fix the desiccant onto the upper substrate.

14. The organic electroluminescent display as claimed in claim 13, wherein the desiccant material layer is composed of at least one material selected from a group consisting of barium oxide (BaO), calcium carbonate (CaCO₃), calcium oxide (CaO), phosphor oxide (P₂O₅), Zeolite, Silicagel, and Alumina.

15. The organic electroluminescent display as claimed in claim 13, wherein the desiccant material layer has a thickness of less than 200 μm.

* * * * *

专利名称(译)	有机电致发光显示器		
公开(公告)号	US20050104513A1	公开(公告)日	2005-05-19
申请号	US10/989022	申请日	2004-11-16
[标]申请(专利权)人(译)	李浩SEOK 崔元KYU		
申请(专利权)人(译)	李浩SEOK 崔元-KYU		
当前申请(专利权)人(译)	三星DISPLAY CO. , LTD.		
[标]发明人	LEE HO SEOK CHOE WON KYU		
发明人	LEE, HO-SEOK CHOE, WON-KYU		
IPC分类号	H05B33/04 B01D53/26 B01J20/16 H01L51/50 H01L51/52 H05B33/00		
CPC分类号	H01L51/5237 H01L51/5259 H01L51/524		
优先权	1020030081209 2003-11-17 KR		
其他公开文献	US7411345		
外部链接	Espacenet USPTO		

摘要(译)

特别地，本发明的一个实施例提供了一种有机电致发光显示器，其包括形成在下绝缘基板上的发光器件，以及安装以封装发光器件的上基板，其中上基板设置有干燥剂，干燥剂形成有至少一个穿过干燥剂的孔。

